

# M6808 Microprocessor Collective

## Lift Control Manual

**TVL No. 131**

**Issue No. 1**

**Date 9/84**

PART 1

MICROPROCESSOR COLLECTIVE

LIFT CONTROL

GENERAL CONTENTS

		PAGE
SECTION 1	INTRODUCTION	5
SECTION 2	INSTALLATION AND COMMISSIONING	13
SECTION 3	OPERATING PROCEDURES	23
SECTION 4	TECHNICAL DESCRIPTION	39
SECTION 5	OVERHAUL AND REPAIR	47
SECTION 6	SPARES LIST	53
SECTION 7	DUPLEX OPERATION	55
SECTION 8	GLOSSARY OF TERMS	59
APPENDIX		63

Issue 1  
Date 9/84

CONTENTS

<u>SECTION 1</u>	<u>INTRODUCTION</u>	Page
1.1	General	6
1.2	Construction	6
1.3	Overall System Description	7
1.4	Performance Characteristics	8
1.4.1	Electrical	8
1.4.2	Mechanical	9
1.5	Microprocessor System Description	9
<u>SECTION 2</u>	<u>INSTALLATION &amp; COMMISSIONING</u>	
2.1	General	14
2.2	Rear Access	14
2.3	Microprocessor Rack Connection to System	14
2.4	Control Panel Switch On	15
2.5	Microprocessor Rack Switch On	15
2.6	Car Calls	16
2.7	Door Park Open Time	17
2.8	Homing	17
2.9	Stuck Push Button	17
2.10	Input/Output Test	17
2.11	Input Signal Functions (I/O Cards)	17
2.12	Output Relay Functions (I/O Cards)	19
<u>SECTION 3</u>	<u>OPERATING PROCEDURES</u>	
3.1	Operation of Controls and Significance of Audible and Visual Indicators	24
	Visual Indicators	
3.1.1	PSU Card	24
3.1.2	AUX Card	24
3.1.3	MEM Card	24
3.1.4	CPU Card	24
3.1.5	I/O Card	24
3.1.6	POS'N Card (Simplex)	25
	Audible Indicators	
3.1.7	Attendant Buzzer	25
3.1.8	Limited Force Door Closing	25
3.1.9	Selfish User Buzzer	25
3.1.10	Engineer Code	25
3.1.11	Event Code	26
3.2	Normal Control	26
3.3	Attendant Control	27
3.4	Fire Control	27
3.5	Service Control	29
3.6	By-pass	29
3.7	Event Messages	30
3.7.1	Recalling of the Event Codes	31
3.7.2	Pushbuttons on AUX Card	31
3.7.3	Leaving the Event Recall Mode	31
3.7.4	Engineers Code	31
3.7.5	Event Code Description	32

<u>SECTION 4</u>	<u>TECHNICAL DESCRIPTION</u>	
4.1	Rack Motherboard	40
4.2	PSU Module (Power Supply)	40
4.3	CPU Card (Central Processing Unit)	41
4.4	MEM Card (Memory)	42
4.5	POS 'N Card (Position)	43
4.6	AUX Card (Auxiliary)	43
4.7	I/O Card (Input/Output Interface)	44

<u>SECTION 5</u>	<u>OVERHAUL AND REPAIR</u>	
5.1	Handling of EPROM's	48
5.2	Fault Finding Procedures	48

<u>SECTION 6</u>	<u>SPARES LIST</u>	53
------------------	--------------------	----

<u>SECTION 7</u>	<u>DUPLEX OPERATION</u>	
7.1	Reference to Duplex Operation	56
7.2	Communication Cable Connection	56
7.3	Technical Description (POS 'N card - Duplex)	57

<u>SECTION 8</u>	<u>GLOSSARY OF TERMS</u>	
8.1	Input Signal Abbreviations	60
8.2	Output Signal Abbreviations	61
8.3	System Abbreviations	62

<u>APPENDIX</u>		63
-----------------	--	----

ILLUSTRATIONS

Fig 2.0	External Wiring (Microprocessor to rest of System)	
Fig 2.2	Main Panel Wiring Diagram	
Fig 4.0	P.S.U. Module Circuit Diagram	
Fig 4.5	I/O Card Circuit Diagram	

SECTION ILLUSTRATIONS

Page

SECTION 1

Fig 1.0	Card Positions in Microprocessor Rack	10
Fig 1.1	Functional Block Diagram of Overall System	11
Fig 1.2	Functional Block Diagram of Microprocessor System	12

SECTION 2

Fig 2.1	8 Floor Collective Lift System (Simplex)	21
---------	--	----

## SECTION 1

### INTRODUCTION

		Page
1.1	General	6
1.2	Construction	6
1.3	Overall System Description	7
1.4	Performance Characteristics	8
1.4.1	Electrical	8
1.4.2	Mechanical	9
1.5	Microprocessor System Description	9

### ILLUSTRATIONS

		Page
Fig. 1.0	Card Positions in Microprocessor Rack	10
Fig. 1.1	Functional Block Diagram of Overall System	11
Fig. 1.2	Functional Block Diagram of Microprocessor System	12

## 1.1 General

The TVLC M6808 Microprocessor Lift Control module is one of a number of modules supplied by TVLC which together make up a lift control system. The module is designed to meet the demand for a more intelligent lift control panel whilst maintaining safety, reliability and cost competitiveness.

In addition to the normal features a number of refinements normally found only in "deluxe" lift installations, are included as standard; these include, for example, recognition of a stuck button (which is consequently ignored), LED indication of each incoming/outgoing signal, a numerical display of lift position and direction of travel, and 'on request' displays of certain past and present lift events.

Features provided by the system include:

- (a) Firemans control and indicator
- (b) Special Service Control
- (c) Homing
- (d) Landing door re-open once
- (e) Light Ray Failure
- (f) Stuck Button Detection
- (g) Differential Door Timing
- (h) Advance Call Cancel
- (j) Optional use of separate door close push
- (k) Weight switch 95% FL. and Bypass indicator
- (l) Car Call Dumping
- (m) Event Message Display
- (n) Door opening and closing protection
- (o) On card, battery back up for lift position and Event Message queue for a minimum of 20 days. Batteries are re-charged automatically upon the return of the supply.

## 1.2 Construction

The system comprises a rack mounted housing containing a motherboard in which a number of printed circuit cards are housed (see Fig 1.0). The motherboard is available in a number of widths depending on the number of floors the lift system is to service e.g. less than 8 floors, between 8 and 12 floors or between 13 and 18 floors. Connections to the motor panel section are achieved via Molex connectors on the rear of the rack. (Shaft wiring and car wiring are via klippon terminals also on the rear of the rack).

An additional rack is necessary for systems over 18 floors.

On the front of the rack there is a plastic transparent cover which is silk screen printed with LED information and incoming/outgoing signal notation. It also prevents ingress of dirt onto the cards etc.

The system voltages are derived from a transformer on the motor panel section, which are fed via a wiring harness and connector to the microprocessor rack, through a second connector to the PSU module (extreme left of rack when viewed from Front), rectified, and fed back to the motherboard to await system use.

The motherboard contains two BUS systems which together form the interconnection system between the various printed circuit cards. The Microprocessor Bus, which contains an 8 line Data Bus and a 28 line Address and Control Bus interconnects the CPU, POSN, MEM and AUX cards and the Interface Bus which contains an 8 line Data Bus and a 9 line Address and Control Bus houses the I/O cards. The Microprocessor Bus and the Interface Bus are interconnected by means of a 40-way ribbon cable header which connects to the AUX card.

### 1.3 Overall System Description (Fig 1.1)

The overall TVLC Microprocessor Collective Lift Control System comprises of a Microprocessor Rack (Ref. Microprocessor System Description SECTION 1 PARA 1.5) and Motor Panel Section plus Shaft and Car wiring.

The Microprocessor Rack is housed above the Motor Panel Section in a single, floor standing cabinet (Simplex only).

The overall system is built around the M6808 Microprocessor, which is used as the control centre for monitoring and addressing all incoming and outgoing signals to the remainder of the system.

The lift motor operation is controlled by the Motor Panel Section which receives signals from the microprocessor rack such as pilot high speed up, pilot high speed down, pilot open doors and pilot close doors, and transmits messages back to the Microprocessor Rack with information regarding which lift function it is carrying out i.e. moving up, moving down, opening/closing doors, door zone or locks made.

The Motor Panel Section also transmits signals to and receives signals from the shaft and car wiring, these being locks and safety circuit signals from the shaft wiring; and door operator, car gate and safety circuit signals from the car wiring.

Signals to and from the shaft and car wiring are also transmitted and received by the Microprocessor Rack, these include landing calls, position indicators, position reset, and fire switch etc. from the shaft wiring; and car calls, position indicators, service switch, attendant control etc. and proximity switches from the car wiring.

High reliability, field proven industrial standard components are used throughout the system and are readily available from many sources.





- . Output Relays
  - . Single change over contact per relay
  - . Contact Rating 5A @ 250V ac
  - . Coil Voltage 24V dc
  - . Card Mounting
  - . 8 relays per I/O card
  - . Common feed to relay outputs with 5A fuse

- POSN Card (Duplex)
  - . +10V dc input to (7805) 5V Regulator
  - . -12V dc for RS-232 serial interface communication

Environmental Range

Humidity Operating Range = 0 to 90% Relative Humidity

Temperature Operating Range = 5° to 40°C ambient

1.4.2 Mechanical

Height	=	243mm
Width	=	481mm
Depth	=	308mm
Weight	=	9kg

1.5 Microprocessor System Description (Fig 1.2)

The microprocessor system comprises a number of printed circuit cards all of which are housed on the motherboard. These are namely:

- (a) A P.S.U. Module from which the system input voltages are derived; the input to the PSU module itself being via a transformer on the Motor Panel Section.
- (b) A C.P.U. Card which contains the M6808 Microprocessor chip, plus a minimum of 20 days battery back up (in case of normal supply failure) for the CMOS RAM (MEM Card). The batteries re-charge on reconnection of the normal supply.
- (c) A number of identical I/O cards, the first three of which are used as interface cards for receiving incoming signals such as door zone and gates locked etc. and exiting outgoing signals for energising the various output relays i.e. lift service available, door close relay etc.

The remaining I/O cards, I/O 4 and above, accept car call and landing call input and output signals.

- (d) A POSN card which indicates the actual position and direction of the lift at any one time.
- (e) A MEM card which contains the EPROM and RAM memory for this system.
- (f) An AUX card which controls the I/O cards Data Bus and various peripheral circuit functions.

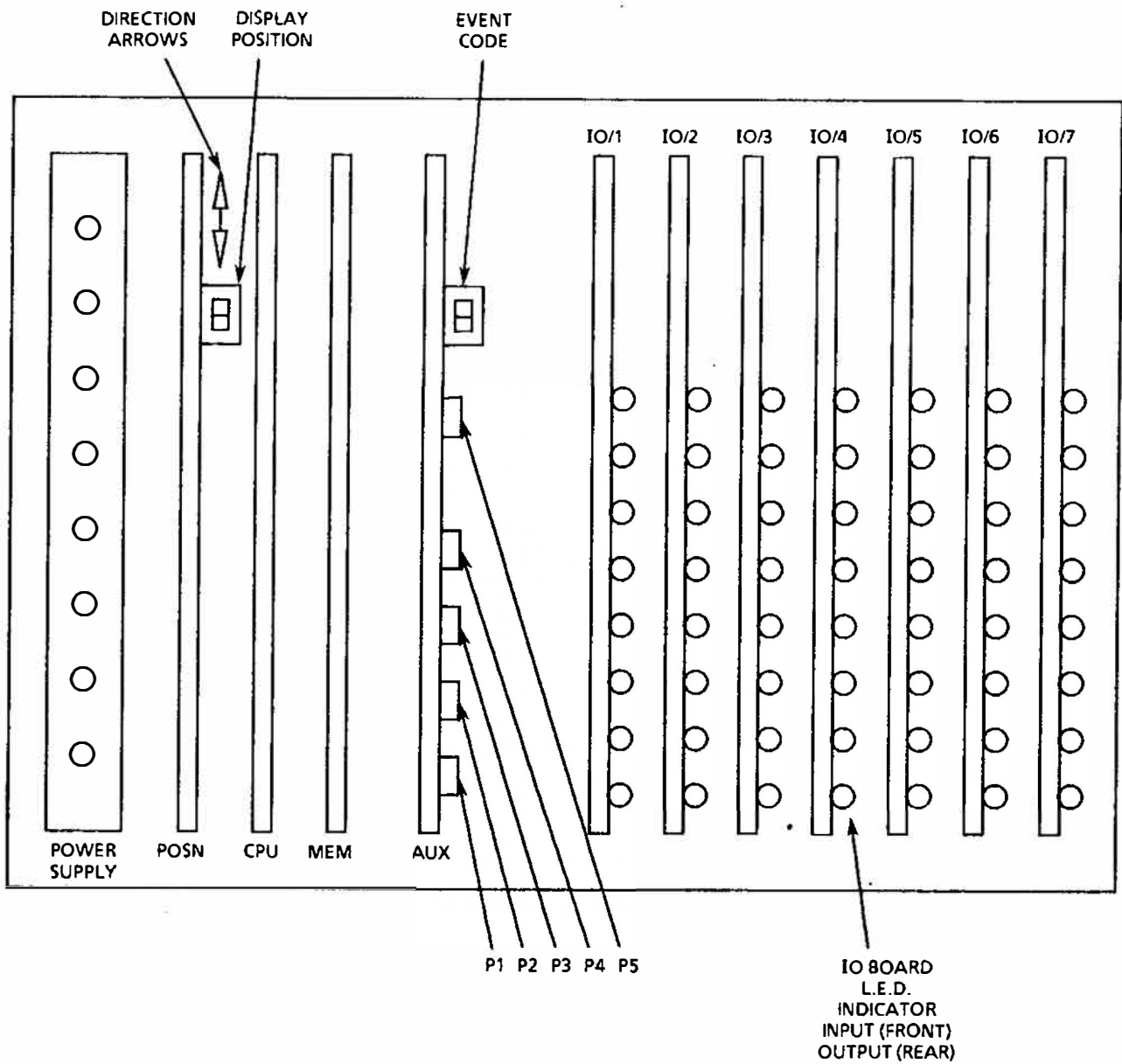

Fig 1.0 Card Positions in Microprocessor Rack

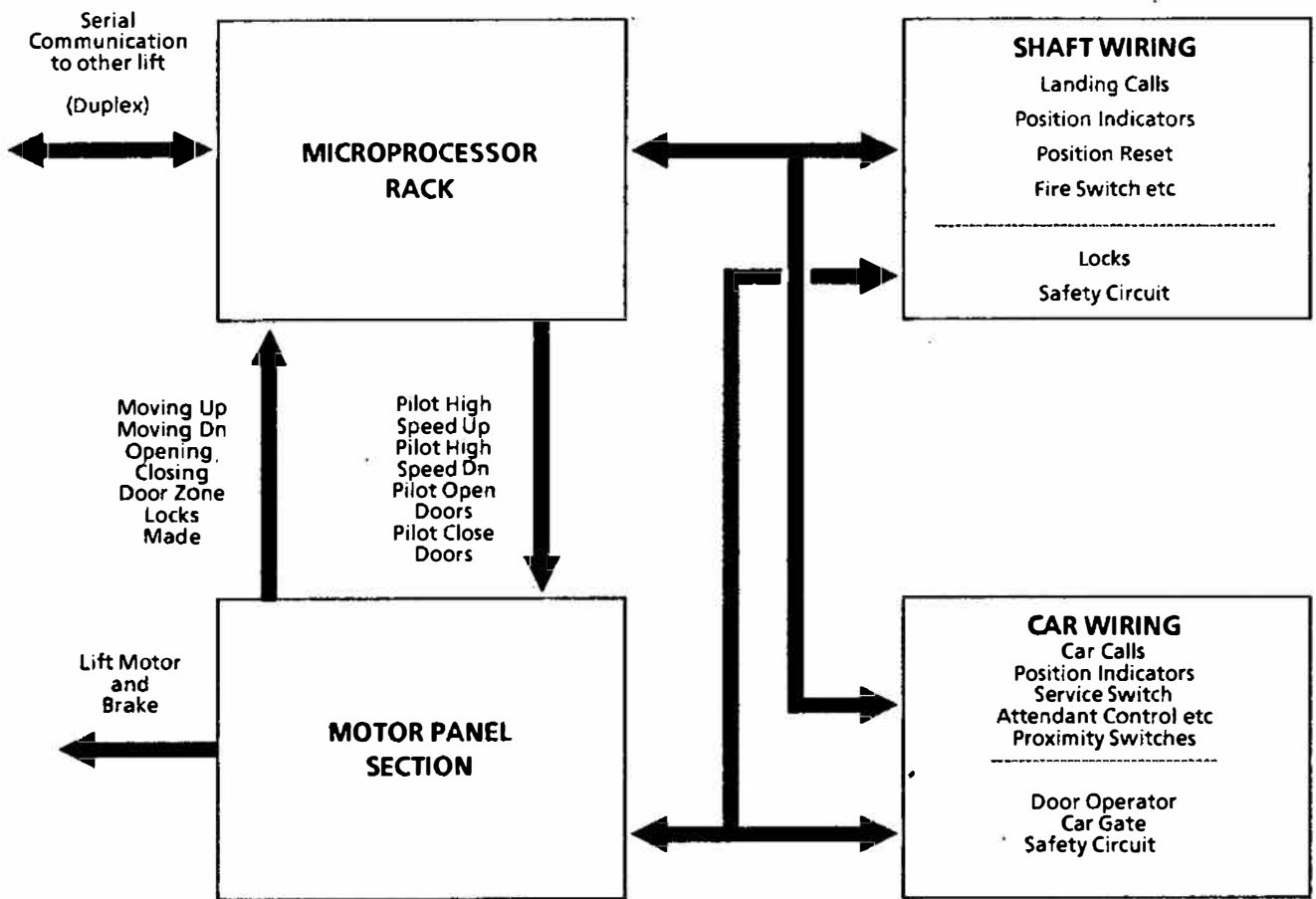
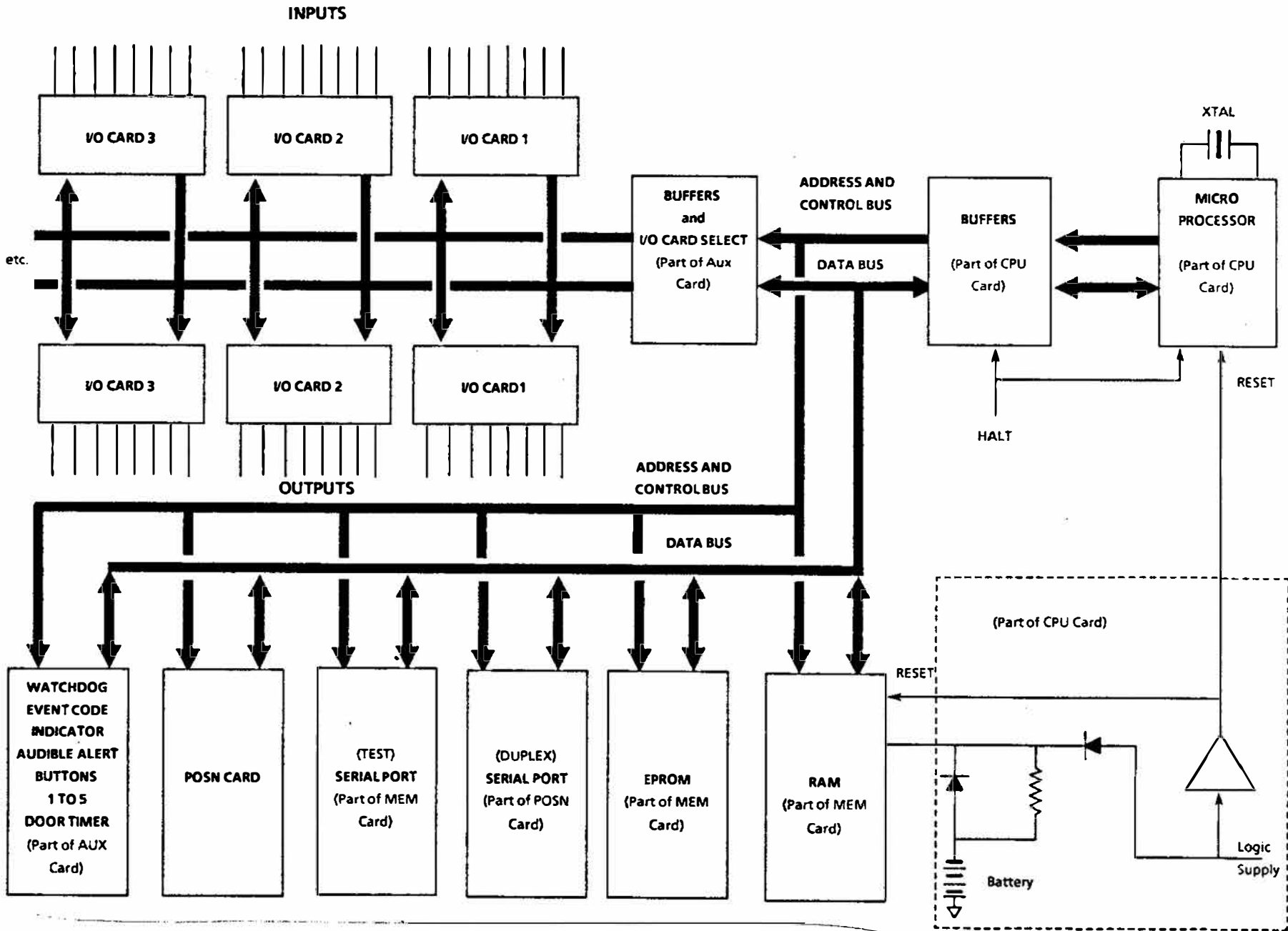

Fig 1.1 Functional Block Diagram of Overall System

Fig 1.2 Functional Block Diagram of Microprocessor System



## SECTION 2

### INSTALLATION AND COMMISSIONING

		Page
2.1	General	14
2.2	Rear Access	14
2.3	Microprocessor Rack Connection to System	14
2.4	Control Panel Switch On	15
2.5	Microprocessor Rack Switch On	15
2.6	Car Calls	16
2.7	Door Park Open Time	17
2.8	Homing	17
2.9	Stuck Push Button	17
2.10	Input/Output Test	17
2.11	Input Signal Functions (I/O Cards)	17
2.12	Output Relay Functions (I/O Cards)	19

### ILLUSTRATIONS

		Page
Fig. 2.1	8 Floor Collective Lift System (Simplex)	21

## 2.1 General

The external wiring for the Microprocessor controlled system is as shown in Fig 2.0. (Ref APPENDIX)

All incoming wiring to the rack including car and landing pushes etc, are at 100V dc and all outgoing wiring for indicators are at 12V ac.

## 2.2 Rear Access

All external wiring to the rack terminals is made at the rear of the rack, therefore access to the control panel rear is normally required.

Wall mounted cabinets can be supplied at extra cost.

During wiring up the rear of the rack, it can be seen that access can be made, if and when required, to the microprocessor Motherboard, by hinging down the terminal board.

The common indicator return (INR) terminal is located at the front with the motor panel terminals, although the indicator terminals are at the rear.

Note To prevent ingress of dust into the microprocessor assembly whilst the controller is being wired up, the printed circuit cards should be plugged into the rack and the perspex front cover fitted.

Bell buzzer use is satisfactory in checking out the wiring.

## 2.3 Microprocessor Rack Connection to System (Ref. Fig 2.0, Fig 2.2 and Fig 4.0 in APPENDIX)

### (a) Transformer Connections

(Transformer is mounted on Motor Panel)

#### (i) Transformer Input

TPN Line (Main Panel) connects to 0V terminal block on transformer.

TPF Line via TPF fuse (Main Panel) connects to 240V terminal block on transformer.

#### (ii) Transformer Output

Transformer outputs go via separate loom to socket 1T on Microprocessor Rack.

**Note:** Keep Input and Output looms separate.

### (b) +100V Line

Connects from Main Panel, by spade terminal to 100V terminal on Microprocessor Rack.

(c) LAR Line

Connects from Main Panel, by spade terminal to LAR terminal on Microprocessor Rack.

(d) Connections to Microprocessor Rack, by spade terminal from Main Panel

	<u>Microprocessor Rack</u>		<u>Main Panel</u>
TO	SP1, SP2, SF4 and SF5	FROM	XF1 Fuse
TO	LF4 and LF5	FROM	XF3 Fuse (or LFF Fuse)
TO	NF1 and NF2	FROM	Neutral

(e) Earthing Strap

From INR on Main Panel to central earth point on Microprocessor Rack.

2.4 Control Panel Switch On

Before switching on for the first time carry out the following procedure:

- (a) Remove perspex front cover.
- (b) Unplug power supply module.
- (c) Pull the I/O (Input/Output) cards out of the microprocessor rack by approximately 1/2 inch.
- (d) Remove fuse TPF, (this is carried out because at this stage microprocessor operation is not required).

Switch on control panel, ensure no 240V ac wiring has been inadvertently connected to the rear of the rack. Special attention should be made to the CT1 and CT2 wiring and the Reset limits SSU and SSD (Top Floor Reset and Bottom Floor Reset respectively).

When the wiring has been fully checked out carry out the reversal of the above procedure.

2.5 Microprocessor Rack Switch On

After switch on, the following checks should be made:

- (a) (i) All the power supply module LED indicators should be illuminated, to show that the various voltages are available and that their related fuses are intact.

(ii) Earth Faults:

Car Push Feed (CPF) earth fault = CPF fuse will blow.

Landing Push Feed (LPF) earth fault = LPF fuse will blow.

Note: CPF and LPF Fuses rely on LAR relay being energised.



(iii) CT1 and CT2 circuit earth fault = 100V fuse will blow.

Note: The LED indicators for CPF and LPF will also be off.

All fuses on the microprocessor rack are 20 mm fuses. Ref PSU, AUX and I/O cards SECTION 4.0 PARAS 4.2, 4.6 and 4.7 respectively.

(b) The green LED on ALL THE CARDS should be illuminated, indicating that the logic supplies to the individual cards are available.

Note: The MEM Card has two LED indicators (two supplies).

(c) On I/O Cards 4 onwards the relative position indicator LED will, from memory, show the last position of the lift when the lift was last switched off. If this position is unacceptable, the lift will assume top floor position and after a short delay will "home" to the bottom floor.

(d) On the CPU card the amber LED designated as "HALT" should be off.

(e) On the MEM card the amber LED designated "CLOCK" should be flashing continually, giving visual indication that the MPU clock is functioning correctly.

(f) On the AUX Card the amber LED designated "LOOP" should be flashing continually, giving visual indication the the MPU is functioning correctly through the program.

For a short time the EVENT CODE will display a "0", or it may be overridden by a "1" which will remain displayed. A "1" indicates that the lift has a primary safety circuit failure due to operation of stop switch etc. i.e. the LAR relay (Lift Available Relay) is de-energised.

Provided the Bleep switch is in the "on" mode, the bleeper will sound for a few seconds everytime an EVENT CODE is displayed.

(g) On the I/O Cards, any red LED illuminated on the front row shows that an incoming signal is present. Ref Fig 2.1 for signal notation. (Perspex Front cover).

The rear row of red LED's indicate which output relay is energised. Ref Fig 2.1 and SECTION 2 PARA 2.12.

Note: A fuse (OIF) on each of the I/O cards, is connected in series with the common feed to the output relay contacts. Ref Fig 4.5 (APPENDIX).

## 2.6

### Car Calls

From the fourth I/O card upwards, car calls can be entered at the microprocessor rack by short circuiting a pair of 'jumper pins' on the front of the card. The corresponding output relay will energise indicating that the car call has been accepted.

2.7 Door Park Open Time

The time the lift doors park open, is adjusted by means of a potentiometer mounted at the front of the AUX Card above the "EVENT CODE" display.

On the perspex front cover it is designated as "DOOR DWELL TIME".

2.8 Homing

The lift will "home" to the bottom floor (or floor specified by customer) when terminals HOM and CT2 are connected together.

2.9 Stuck Push Button

The MPU automatically reads the input signal when the push button is depressed, memorises it and compares it with the previous input signal.

If both signals are the same, the system operates normally.

If the signals differ, the operational command signal is ignored by the system until the stuck button is released and re-operated.

2.10 Input/Output Test

To test operation of I/O circuits proceed as follows:

- (a) Pull first I/O card out of the Motherboard by approx. 1/2 inch.
- (b) Depress Button 4 and Button 5 on the AUX Card, simultaneously (Fourth and Fifth Button up from the bottom edge of card - Blue and Red respectively).
- (c) Short circuit the pins on the front edge of the other I/O cards in turn to simulate an incoming signal. The appropriate O/P relay will energise and its corresponding LED will illuminate depicting correct functioning of the I/O circuit.

Note: Buttons 4 and 5 on the AUX card have to be depressed approximately every 5 seconds throughout the test period.

2.11 Input Signal Functions (I/O cards)

Going from top to bottom of each card.

I/O Card 1 (8 I/P Functions)

LAR	=	Lift Available
OC	=	Open Contactor
CC	=	Close Contactor
DZ	=	Door Zone
U	=	Up Contactor
D	=	Down Contactor
GL	=	Gates Locked
PTT	=	Prepare To Take Out

I/O Card 2 (8 I/P Functions)

WS1 = Weight Switch 95%  
\* WS2 = Weight Switch 110%  
SSR = Service Control  
ATS = Attendant Control  
AU = Attendant Up Push  
AD = Attendant Dn Push  
BP = Attendant By-pass  
FS2 = Firemans Switch

I/O Card 3 (8 I/P Functions)

DCP = Door Close Push  
ANUI = Anti Nuisance Inhibit  
MRHX = Step Prox High Speed  
MRMX = Step Prox Med Speed  
MRLX = Step Prox Low Speed  
SE = Safety Edge  
DOP = Door Open Push  
\* BB = Beam Broken

I/O Card 4 (8 I/P Functions)

SSD = Bottom Floor Reset  
CP1 = Car Push 1  
L1U = Up Landing Call 1  
MSFR = Mid Shaft Floor Reset  
SSU = Top Floor Reset  
CP2 = Car Push 2  
L2U = Up Landing Call 2  
L2D = Dn Landing Call 2

I/O Card 5 (8 I/P Functions)

CFS = Car Call Feed Supply  
CP3 = Car Push 3  
L3U = Up Landing Call 3  
L3D = Dn Landing Call 3  
LFS = Landing Call Feed Supply  
CP4 = Car Push 4  
L4U = Up Landing Call 4  
L4D = Dn Landing Call 4

I/O Card 6 (8 I/P Functions)

HOM = Homing Switch  
CP5 = Car Push 5  
L5U = Up Landing Call 5  
L5D = Dn Landing Call 5  
LISE = Lift In Service Enable  
CP6 = Car Push 6  
L6U = Up Landing Call 6  
L6D = Dn Landing Call 6

I/O Card 7 (8 I/P Functions)

DPK = Down Peak Time Switch Input  
CP7 = Car Push 7  
L7U = Up Landing Call 7  
L7D = Dn Landing Call 7  
UPK = Up Peak Time Switch Input  
CP8 = Car Push 8  
L8U = Up Landing Call 8  
L8D = Dn Landing Call 8

I/O Card 8 (8 I/P Functions) (When applicable)

AFS = Alternative Fire Floor Signal  
CP9 = Car Push 9  
L9U = Up Landing Call 9  
L9D = Dn Landing Call 9  
EQK = Earthquake Emergency Stop Signal  
CP10 = Car Push 10  
L10U = Up Landing Call 10  
L10D = Dn Landing Call 10

\* For the U.S. Market : WS2 is changed to FS4 (Fire Control Phase 2)  
& BB is changed to RST (Car Call Reset)

2.12 Output Relay Functions (I/O cards)

Going from top to bottom of each card.

I/O Card 1 (8 O/P Functions)

HSR = Lift High Speed Relay (Optional)  
SUR = Lift Speed Up Relay  
SDR = Lift Speed Down Relay  
LSA = Lift Service Available Relay  
DOPR = Door Open Relay  
ROPR = Lift Rear Open Relay  
DCLR = Door Close Relay  
DBZ = Door Nudging Relay

I/O Card 2 (8 O/P Functions)

BPI = By Pass Indicator Relay  
HLU = Hall Lantern Up Relay  
HLD = Hall Lantern Down Relay  
AGR = Arrival Gong Relay  
BZ = Car Buzzer Relay  
FCI = Fire Control Indicator Relay  
IU = Indicator Up Relay  
ID = Indicator Down Relay

I/O Card 3 (5 O/P Functions)

FSX = Fire Service Pilot Relay  
FCR = Fire Service Return Relay  
TCN = This Car Next relay  
HMF I = Heavy Main Floor Relay  
HDDI = Heavy Down Demand Relay

I/O Card 4 (7 O/P Functions)

PI1 =	Lift Position Indicator Relay	[ ]	Floor 1
CA1 =	Car Call Acceptance Relay		
I1U =	Landing Call-Up Acceptance Relay		
PI2 =	Lift Position Indicator Relay	[ ]	Floor 2
CA2 =	Car Call Acceptance Relay		
I2U =	Landing Call-Up Acceptance Relay		
I2D =	Landing Call-Down Acceptance Relay		

I/O Card 5 (8 O/P Functions)

PI3 =	Lift Position Indicator Relay	[ ]	Floor 3
CA3 =	Car Call Acceptance Relay		
I3U =	Landing Call-Up Acceptance Relay		
I3D =	Landing Call-Down Acceptance Relay		
PI4 =	Lift Position Indicator Relay	[ ]	Floor 4
CA4 =	Car Call Acceptance Relay		
I4U =	Landing Call-Up Acceptance Relay		
I4D =	Landing Call-Down Acceptance Relay		

I/O Card 6 (8 O/P Functions)

PI5 =	Lift Position Indicator Relay	[ ]	Floor 5
CA5 =	Car Call Acceptance Relay		
I5U =	Landing Call-Up Acceptance Relay		
I5D =	Landing Call-Down Acceptance Relay		
PI6 =	Lift Position Indicator Relay	[ ]	Floor 6
CA6 =	Car Call Acceptance Relay		
I6U =	Landing Call-Up Acceptance Relay		
I6D =	Landing Call-Down Acceptance Relay		

I/O Card 7 (8 O/P Functions)

PI7 =	Lift Position Indicator Relay	[ ]	Floor 7
CA7 =	Car Call Acceptance Relay		
I7U =	Landing Call-Up Acceptance Relay		
I7D =	Landing Call-Down Acceptance Relay		
PI8 =	Lift Position Indicator Relay	[ ]	Floor 8
CA8 =	Car Call Acceptance Relay		
I8U =	Landing Call-Up Acceptance Relay		
I8D =	Landing Call-Down Acceptance Relay		

If the system is greater than an 8 Floor Full Collective as outlined above, the sequence derived from I/O cards 4 to 7 continues, the floor count being incremented by 1, until system requirements are reached.

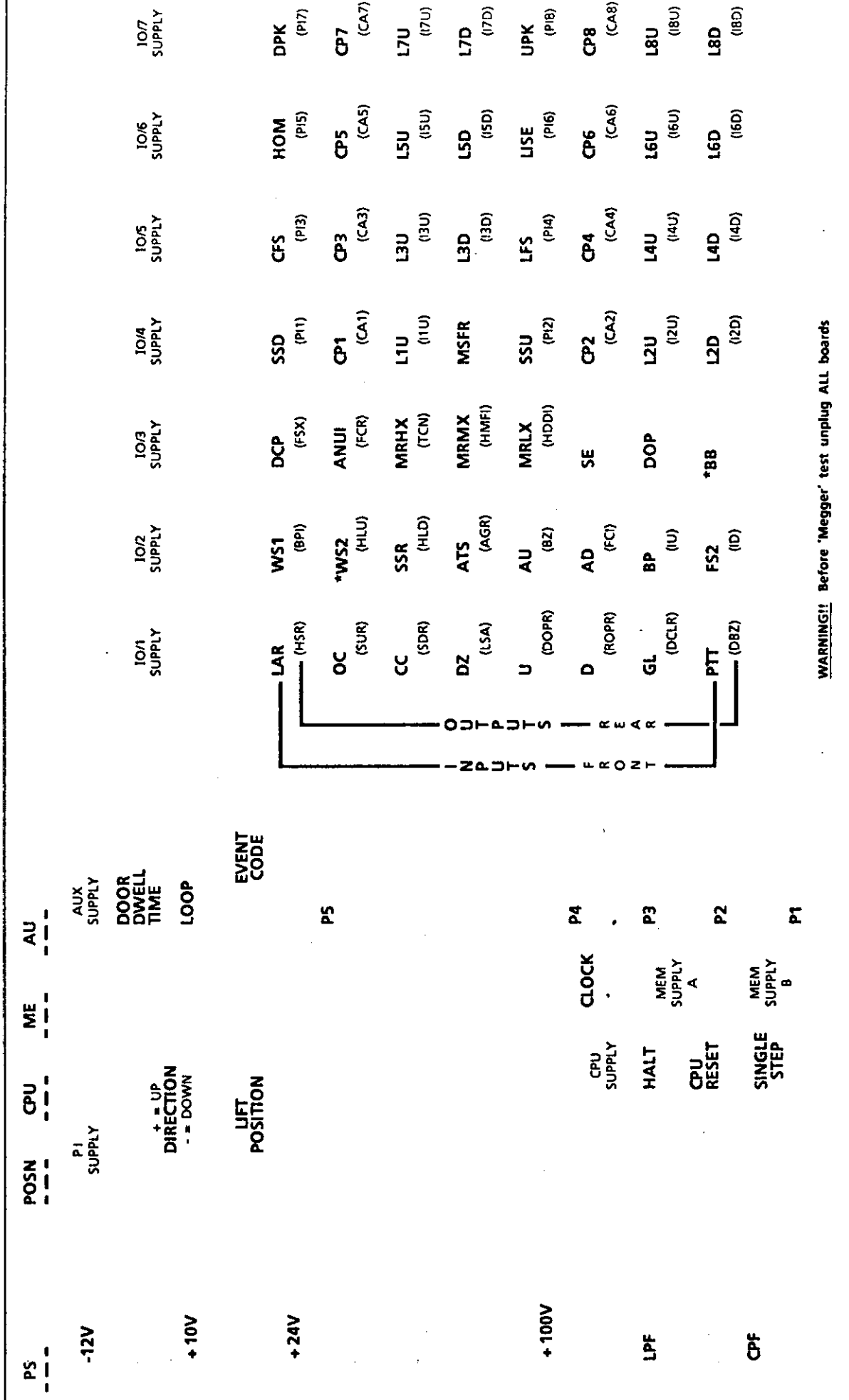

**WARNING!!** Before 'Megger' test unplug ALL boards

\* For the U.S. Market WS2 is changed to FS4 & BB is changed to RST

Fig 2.1 8 Floor Collective Lift System (Simplex)



## SECTION 3

### OPERATING PROCEDURES

	Page
3.1 Operation of Controls and Significance of Audible and Visual Indicators	24
Visual Indicators	
3.1.1 PSU Card	24
3.1.2 AUX Card	24
3.1.3 MEM Card	24
3.1.4 CPU Card	24
3.1.5 I/O Card	24
3.1.6 POS'N Card (Simplex)	25
Audible Indicators	
3.1.7 Attendant Buzzer	25
3.1.8 Limited Force Door Closing	25
3.1.9 Selfish User Buzzer	25
3.1.10 Engineer Code	25
3.1.11 Event Code	26
3.2 Normal Control	26
3.3 Attendant Control	27
3.4 Fire Control	27
3.5 Service Control	29
3.6 By-Pass	29
3.7 Event Messages	30
3.7.1 Recalling of the Event Codes	31
3.7.2 Pushbuttons on AUX Card	31
3.7.3 Leaving the Event Recall Mode	31
3.7.4 Engineers Code	31
3.7.5 Event Code Description	32



### 3.1 Operation of Controls and Significance of Audible and Visual Indicators

#### Visual Indicators (Fig 2.1)

##### 3.1.1 P.S.U. Card

Each output from the P.S.U. card has a red LED associated with it to indicate that power is available to the system, also they show that their relevant fuses are intact. There is an LED for each individual output, these being -12V, +10V, +24V, +100V, LPF (Landing Push Feed) and CPF (Car Push Feed).

##### 3.1.2 AUX Card

- (a) Flashing amber LED - indicate normal operation of the microprocessor through the loop program. If the microprocessor becomes "stuck" in the loop the LED will cease to flash.
- (b) Green LED - indicates that the 5V logic supply is available to the card.
- (c) EVENT CODE DISPLAY - This shows the EVENT CODE and displays it for approximately 5 seconds (this is accompanied by an audible warning).

##### 3.1.3 MEM Card

- (a) Flashing amber LED - Flashes at 1 second intervals to indicate micro-processor clock is functioning correctly.  
(Marked 'CLOCK')
- (b) Green LED's (2) - They indicate that both 5V logic supplies are available to the card.

##### 3.1.4 CPU Card

- (a) Amber LED - 'OFF' in normal state and illuminates when micro-processor is in the 'HALT' state.
- (b) Green LED - indicates that the 5V logic supply is available to the card.

##### 3.1.5 I/O Cards

- (a) Red LED's - Input LED's - LED 1 to LED 8 inclusive - any illuminated LED indicates an incoming signal is present.  
(Front edge of card)
- (b) Red LED's - Output LED's - LED 9 to LED 16 inclusive - any illuminated LED indicates an energised relay.  
(Rear of card)
- (c) Green LED - indicates that the 5V logic supply is available to the card.

### 3.1.6 POS'N Card (Simplex)

- (a) Amber LED's (2) - indicates direction of lift travel ie 'UP' ( $\Delta$ ) or 'DN' ( $\nabla$ ).
- (b) Green LED - . indicates that the 5V logic supply is available to the card.  
- . Displays present position of lift.
- (c) POS'N Indicator Display . Displays position of lift when an EVENT occurs (When P1 on AUX card pressed). The "decimal point" is also illuminated as a reminder that the position shown is not necessarily the present position of the lift.  
. Displays number of times an EVENT occurred (when P2 on AUX card pressed).  
. Displays number of days ago EVENT occurred. An "0" display indicates the present day (when P3 on AUX card pressed).

### Audible Indicators

#### 3.1.7 Attendant Buzzer

A buzzer which sounds discontinuously at the Attendant panel in the car if the attendant fails to respond to demand for service.

#### 3.1.8 Limited Force Door Closing (Event Code F.) (optional)

Car mounted buzzer which sounds discontinuously if any of the following conditions occur.

- (a) Four door reversals have occurred.
- (b) Doors fail to close in 25 seconds due to being held open by the safety edge or, door open push.

#### 3.1.9 Selfish User Buzzer (Event Code C.)

Car mounted buzzer sounds discontinuously to encourage occupants to let the lift go.

#### 3.1.10 Engineers Code

When the engineer enters the code ie "≡", a 'bleep' warning will accompany it.

### 3.1.11 Event Code

A 'bleep' warning is initiated when an EVENT CODE is registered.

### 3.2 Normal Control (Simplex Full Collective)

Momentary operation of a car or landing push will register that call and its related call-acceptance indicator will be illuminated.

**Car calls:** Car calls will be intercepted in the order in which the destinations are reached, regardless of sequence in which they were registered or direction of the lift. Car calls are cancelled on intercept at the appropriate landing.

**Landing calls:** Landing calls are cancelled on intercept at the appropriate landing and that the car is available to accept that particular call. When travelling up, the car will stop at a landing for which a car or an up landing call has been registered, but will not stop at landings at which only a down call is outstanding, unless the down call is the highest call outstanding.

Similarly, when travelling down, the car will not stop at a landing at which only an up call is outstanding, unless this is the lowest call outstanding. If the car stops at a landing at which both up and down calls are registered, only the call for the direction in which the car is committed will be cancelled. Should a car without registered car calls arrive at a landing at which both up and down calls are registered only the landing call for the last direction of travel will be cancelled and the direction indicator will remain illuminated. If no car call is inserted the doors will close after the preset interval and if there is then no landing call registered beyond this floor in the last direction of travel, the doors will re-open and cancel the other landing call.

If the car fails to start in response to calls within 100 seconds all calls will be cancelled.

The doors are normally arranged to park closed. When fully open, momentary operation of any car-call push will cause the doors to close immediately, otherwise the doors will close automatically after a pre-set interval has elapsed. The safe-edge contact or output contacts of the light-ray equipment connects directly into the logic unit and will still function even with relatively high contact resistance.

The opening of the doors cannot be prevented by continuous operation of a car push or Door Close push.

### 3.3

#### Attendant Control

Attendant control is established by closing a single-pole switch in the car, which allows the attendant start pushes and pilot direction indicators to become operational. The doors again park open and may now only be closed by continuous operation of the attendant start pushes. All calls are registered in the normal way, but cannot of themselves either close the doors or start the car. The logic system determines a preferred direction and illuminates only the appropriate attendant pilot direction indicator, but the attendant is free to ignore this and override it by pressing the opposite direction push to close the doors and start the car. He cannot override the preferred direction once the car has started. When the attendant operates a start push the appropriate main direction indicators are illuminated. Also the car will not start in the opposite direction unless calls actually exist for that direction. The calls will only be cancelled on intercept as on automatic.

Should the attendant fail to respond to a demand for service within a pre-set time after the doors have opened, a car-mounted buzzer will begin to sound discontinuously until he starts the doors to close. If he fails to take action within 100 seconds then the outstanding calls are cancelled and the buzzer ceases operation.

At any time after lift has started, the attendant may, by momentary operation of a by-pass push button, cause all landing calls to be by-passed and the car to proceed to the nearest car call outstanding in the direction in which it is moving. If only landing calls were outstanding the car would travel to the furthest such call in the direction of travel.

### 3.4

#### Fire Control

##### (a) UK Version

Closing of a single-pole switch at the main landing will immediately cancel all outstanding calls, and if travelling away from the main floor, cause the car to slow and stop at the first available landing, whereupon the doors will remain closed and the car after a short period of time start and return to the main floor. If travelling toward the main floor when the switch was closed, it will proceed without interruption to the main floor. If when the switch was closed the car was at a landing with the doors open, the doors will close immediately and the car start and return to the main floor. Once at the main floor, the doors will open, park open and operation of the car pushes will be restored on car-only control similar to "SERVICE" (ref SECTION 3 PARA 3.5).

The fire-control switch can be operated with the car anywhere in the shaft or at any point in its operating sequence, without resulting in failure of the car to return to the main floor as required. The light-ray contact is cut-out on fire control.

(b) U.S. Version

Firemans Control consists of two phases of service. Phase I operation covers the control during the lifts return to the fire return floor. Phase II operation covers the control of the lift after it has returned to the fire return floor, when it is switched to operation by the fireman from the car.

PHASE I OPERATION

Phase I control may be initiated by the operation of the firemans return switch at the fire return floor landing. Alternatively, if fire sensors are fitted on each landing operation of the sensors may initialise Phase I control. When sensors are fitted, a manual override control switch may be included at the main floor in order to deactivate the sensors control should they be operating under a faulty condition.

When Phase I is operating:

- (1) The car returns to the designated level where the doors open and remain open.
- (2) A car travelling away from the designated level will reverse at the next available floor and without opening its doors return to the designated level.
- (3) A car stopped at a landing will have the in-car emergency switch rendered inoperative as soon as the door is closed. Moving cars will have the in-car emergency rendered inoperative immediately.
- (4) Door re-opening devices sensitive to smoke or flame such as light ray units are rendered inoperative. Safety edges remain operational.
- (5) All car and landing call pushes become inoperative.
- (6) An audible and visual indication is given to warn passengers that the car is returning under fire control.

When smoke or fire detectors are incorporated into the system they shall be wired such that the main floor sensor is separate to the other floor sensors. Operation of the sensors shall return the lift to the designated floor under Phase I control, but if the main floor sensor is activated the lift will be returned to an alternative fire return floor, normally one floor above the normal fire return floor.

After return to the designated fire floor the lift will remain with its doors open with all car and landing call pushes inoperative.

PHASE II OPERATION

Providing a lift has returned and is under Phase I control, then operation of the Phase II switch in the car shall commence Phase II operation.

When Phase II is operating:

- (1) The lift is controlled only by persons in the car.
- (2) All landing calls become inoperative.
- (3) The opening of power doors will be controlled only by the continuous pressure 'open' button in the car, if the push is released before the doors reach the fully open position then they automatically re-close.
- (4) Closing of the doors once fully open will be initiated by registration of a car call and operation of the door close push.
- (5) Door re-opening devices as Phase I item (4) shall remain inoperative.
- (6) Registered calls may be cancelled by operation of the 'reset' push in the car.
- (7) The lift will only be removed from Phase II by switching off the Phase II switch in the car, with the car positioned at the designated or alternate fire return floor. Removal of the Phase I signal after Phase II is initiated shall not release Phase II.

Lifts operating on top of car inspection shall not return to the fire floor, but audible warning will be given on the car to signal the engineer of the fire operation requirement.

### 3.5 Service Control

Service or car-only control is established by operation of a single pole key-switch in the car. All outstanding calls are cancelled and landing calls cannot be registered.

On SERVICE CONTROL the system is non-collective and all outstanding car calls will be cancelled whenever the doors fully open. If more than one car call push is operated simultaneously then the car will travel to the nearest and all will be cancelled when the doors open.

### 3.6 By-pass

If the car is fitted with a load sensing switch and this switch is closed when the doors are closing, then the by-pass feature operates so that the car cannot stop for intermediate landing calls and will only stop at the first car call encountered.

Acceleration or retardation cannot cause inadvertant operation of the by-pass feature.

The Microprocessor system is able to recognise specific events during the operation of the lift. These events are as follows:

CODE	EVENT
(0)	Switch-on Reset sequence.
(1)	Primary safety circuit failure. (i.e. Stop switch).
(2)	Program loop failure.
(3)	Lift stopped outside door zone.
(4)	Door opening protection fault.
(5)	Gate lock fault.
(6)	Gate lock tipped on high speed.
(7)	Gate lock tipped on slow speed.
(8)	Gate pre-lock failure.
(9)	Door closing protection fault.
(A)	Weight switch. 110% FL.
(B)	Lift engineer in attendance. (Three "bars" displayed).
(C)	Landing calls transferred. (Multi-car systems). 1st occurrence Landing and car calls cancelled. 2nd occurrence
(E)	Shut-down due to 3 successive attempts to start.
(F)	Limited force Door closing.
(H)	Memory failure.
(J)	Program "Stack" error.
(L)	"LISI" extinguished.
(P)	Program error.
( )	Start failure.
(U)	Safety-Edge-Overtime
(c)	Car push feed lost
(L)	Landing push feed lost
(u)	User defined.

"User defined" means the user may have an event recorded of his own choosing.

Whenever one of these events occurs, the system will display the Event Code for approximately 5 seconds and "bleep" a warning. The code is also stored in a queue in memory together with the position of the lift when the event occurred.

If the code and the position of the lift is the same as the previous entry in the queue, the code will not be added to the queue, but a memory location attached to this code, will be incremented. It can therefore be determined how many times this event occurred.

Also attached to each event in the queue, is a memory location which is incremented approximately every 24 hours so that it can be determined how many days ago the event occurred.

Up to 20 events can be stored in the queue. Introducing another entry will cause the oldest event in the queue to be lost.

An automatically rechargeable battery is used to support memory retention, in the event of supply failure, for at least 20 days.

### 3.7.1 Recalling of The Event Codes

Recalling the Event codes does not interfere with normal lift service and can be done at any time provided that the supply is available. While in the Recall mode, new events are still recognised and entered into the queue.

### 3.7.2 Pushbuttons on AUX Card (Figs 1.0 & 2.1)

Pressing Button P1 once, on the AUX card, will cause the most recent Event code to be displayed. At the same time, the local Position Indicator (on the POS'N card), will display the position of the lift when that event occurred. The "decimal point" is also illuminated as a reminder that the position shown, is not necessarily the present position of the lift.

Pressing Button P2, will cause the local position indicator to display the number of times this event occurred.

Pressing Button P3, will cause the local position indicator to display the number of days ago that this event occurred. A "0" being displayed, indicates today.

Pressing Button P1 once again, will cause the next, (that is the preceding), Event code to be displayed, and the local position indicator will again display the lift position when that event occurred. Operation of Buttons P2 and P3, (which is optional), is again as described above.

Stepping through the event queue is therefore effected by pressing Button P1. Following the oldest event, a hyphen "-" will be displayed. Pressing Button P1 once again, will recall the first most recent Event again.

### 3.7.3 Leaving The Event Recall Mode (Figs 1.0 & 2.1)

Pressing the red Button P5 will cause a hyphen "-" to be displayed and after 2 seconds, the local position indicator will then show the present position of the lift.

This mode will also automatically exit itself, in the event that no Button has been operated for 20 seconds.

### 3.7.4 Engineers Code

Upon completion of a lift repair, provided there is no event code being displayed, the Engineer can input an Engineers code by pressing Button P4 (AUX Card), this creates a 'three bar' display, "≡", on the local Position Indicator (POS'N Card) and an audible warning. (Code "B" will be automatically entered onto the event queue).



On his next visit the Engineer can step through the event queue by pressing Button P1 (AUX Card) until the 'three bars' are displayed, all event codes prior to this display have occurred since the previous visit.

### 3.7.5 Event Code Description

#### (0) Switch-On Sequence

When the lift is switched on, the Microprocessor Unit (MPU), will begin its reset routine, write a "0" on to the Event Code display and store it in the event queue and then enter the lift program.

The MPU can also be manually reset at any time by operation of the "RESET PUSH" on the CPU card.

#### (1) Primary Safety Circuit Failure

The LAR Relay (Lift Available Relay), on the motor panel provides this signal to the MPU. Whenever LAR Relay is de-energised, for example, due to the stop switch operated, or the lift switched to maintenance control, a code "1" will be displayed.

The code "1" will remain displayed while this situation continues to exist. All car and hall calls will be cancelled and the "LSA" (Lift Service Available) indicator will be off. (This LSA indicator is only provided when requested).

#### (2) Program Loop Failure

This indicates that the MPU was unable to function properly through part of the lift program, such that it gets "stuck" and nothing else gets done. (Under normal circumstances this is unlikely to occur, but it is included for completeness).

After a short delay, the "Loop Flag Monitor" on the AUX card, will deliberately reset the MPU. The MPU will again enter its reset routine, generate a code "0", and re-enter the lift program.

Part of the reset routine checks to see whether the call to reset was made by the "Loop Flag Monitor" circuit. If true, the MPU will also generate a code "2".

#### (3) Lift Stopped Outside Door Zone

Here an attempt has been made by the MPU, to pilot open the doors but the "Door Open Contactor" (OC), has not energised. After a short delay and the "Door Zone Relay" (DZ) not energising, a code "3" will be generated. The MPU will then seek another car or hall call elsewhere, to send the lift to.

This fault, for example, could be caused by a gate lock tip on low speed, or "Low Speed Time Limit" (LSTLR) time-out.

(4) Door Opening Protection Fault

This is when the doors have failed to finish opening within 15 seconds. A code "4" will be generated, the MPU will stop piloting the "Door Open Contactor" (OC), and the "LSA" indicator will be cancelled. After a short delay the MPU will pilot the doors to close, so that the lift may move to another floor.

This fault, for example, could be caused by an obstruction in the landing door track.

(5) Gate Lock Fault

The lift is idle with the doors closed and with the gate locks made up. If a gate lock is then broken, a code "5" will be generated. The code "5" will remain displayed while this situation continues to exist.

This code can occur through excessive gate lock bounce, or by someone opening a landing door (not necessarily at the same floor as the lift's position).

(6) Gate Lock Tipped on High Speed

Tipping a gate lock on high speed will cause the lift to stop immediately. The MPU will note this by generating a code "6".

After a short delay, the lift will re-start provided that the gate lock has re-made. If the gate lock is still broken, a code "5" (Gate Lock Fault), will be generated as well.

(7) Gate Lock Tipped On Low Speed

Tipping a gate lock on deceleration or slow speed will cause the lift to stop immediately. The MPU will note this by generating a code "7".

After a short delay, the lift will try to open the doors, (since it is most likely that the lift was intercepting that floor, in response to a call registered there). If the lift is in the door zone, the doors will open.

If the lift is not in the door zone, a code "3" will be generated. The lift will then re-start provided that the gate lock is re-made and there are calls elsewhere. If the gate lock is still broken, a code "5" will also be generated.

(8) Gate Pre-Lock Failure

In this case, the lift is in the door zone, but unable to move in response to a call because of lock failure. A code "8" will be generated and the lift will re-open its doors in order to make another attempt to close and make up the gate lock.

After three unsuccessful attempts to start, the lift will then park with its doors open and a code "E" will be generated. (see code "E").

(9) Door Closing Protection Fault

This is when the doors have failed to finish closing within 15 seconds. A code "9" will be generated, the doors will reverse and park open, all calls will be cancelled. The "LSA" indicator will also be cancelled.

Prior to this situation occurring and that there are calls present, the MPU will reverse the doors if they failed to finish closing within 7 seconds, (without a code "9" generated or call loss etc.). Three attempts are made to close within 7 seconds and then the doors will go for the full 15 seconds to close.

Following a door closing protection fault, the doors will park open and will only close again if a car or hall call is operated. If a door closing protection fault occurs again, the lift will then only respond to car calls.

This fault may be caused by an obstruction in the door track, or persons reluctant to move clear of the doors.

(A) Weight Switch 110% Full Load

WS2 Relay on the motor panel will illuminate the "Overload Warning" indicator in the car. The MPU will generate a code "A", cause the doors to re-open and refuse to close until the load is reduced. The code "A" will remain displayed while this situation continues to exist. (WS2 Relay is only fitted when an "Overload Warning" indicator has been specified).

(B) Lift Engineer's Entry

Pressing button "P4" on the AUX card will cause the MPU to write "three bars" on the event code display and store it in the event queue.

On his (or her) next visit to the lift installation, the engineer can interrogate the MPU to find out what faults have occurred since the last visit.

(C) Call Transfer

If the lift has not moved in response to calls present for over 50 seconds, hall calls to which it should have attended will be released to the other lift (if one exists) a code "C" will be generated and the "LSA" indicator will be cancelled.

If "Limited Force Door Closing" feature has not been specified, the MPU will sound a "Selfish User Buzzer" discontinuously (if fitted), in the lift car, in order to encourage the occupant to let the lift go.

If the lift still has not moved in response to calls present for over 100 seconds all car calls will be cancelled. The Buzzer will stop and the "LSA" indicator will remain cancelled. If the lift is operating as a simplex, all hall calls will be cancelled as well.

(E) Three Unsuccessful Attempts To Start

After three successive pre-lock failure (code "8"), or three start failures (code "4"), all car calls will be cancelled, hall calls released, the "LSA" indicator cancelled, and a code "E" generated.

The lift doors will park open and will only close again if a car or a hall call is operated. If another code "E" is again generated, following a further three unsuccessful attempts to start, the doors will again park open, but will only respond to car calls.

(F) Limited Force Door Closing

(Or "Door Nudging"). This feature is only available if the door operator is suitable.

Provided that there are calls present, limited force door closing will come into operation if the doors are held open for over 25 seconds by safety edge or door open push, or that there has been 4 door reversals caused by the safety edge, light-ray etc.

A buzzer will sound discontinuously in the lift car, and the doors will close under limited force disregarding safety edge or light-ray operation. (The door open push is still effective in reversing and holding open the doors, but the doors will start closing immediately the door open push is released).

If the doors fail to finish closing after 15 seconds, so that the lift can move, door close protection will operate and a code "9" will be generated. The doors will then reverse and park open. (see code "9").

(H) Memory Fault

The MPU has found fault with the integrity of its RAM. (Included for completeness).

(J) Program "Stack" error

The MPU has found fault with its "Book keeping" and has reset its "Stack Pointer". (Included for completeness).

(L) "LISI" Extinguished

(Lift in Service Indicator). If the lift has been idle for more than 10 minutes, it will test itself by going to an adjacent floor and returning, seeking a ... (Lift moving - Lift stopped - Doors opening) ... sequence of events. If this sequence does not occur within defined time limits, the "LSA" is cancelled. Another attempt after a further 10 minutes of idleness for confirmation.

If all is well, no further attempts will be made. If again another failure, a code "L" will be generated, the doors will park open, and the lift will only try to respond to car calls.

The lift will automatically test itself if the lift has been moving or has its doors open for an unusually long time.

(P) Program Error

The MPU has added up all its program instructions and data and the resultant number does not match with a "Checksum" number also fixed into the program. (Included for completeness).

(L) Start Failure

The MPU has signalled for the lift to start and the lift has not done so. After a short delay, the lift doors will re-open and a code "L" will be generated.

After three unsuccessful attempts to start, the lift will then park with its door open and event code "E" will be generated.

This fault, for example, could be caused by operation of the "Phase Failure and Reversal Relay" (PFRR), or the Motor Overload Trip.

(U) Safety Edge

If the lift doors are held open by continuous operation of the safety edge for more than 15 seconds a code "U" will be generated.

(c) Car Push Feed Lost

The feed to the car push is lost, could be caused by blown CPF fuse - on this event occurring a code "c" will be generated.

(L) Landing Push Feed Lost

The feed to the landing push is lost, could be caused by blown LPF fuse - on this event occurring a code "L" will be generated.

(u) User Defined

The user may request another specific event which may be recognised by the MPU - On this event occurring a code "u" will be generated.





SECTION 4

TECHNICAL DESCRIPTION

		Page
4.1	Rack Motherboard	40
4.2	PSU Module (Power Supply)	40
4.3	CPU Card (Central Processing Unit)	41
4.4	MEM Card (Memory)	42
4.5	POS'N Card (Position)	43
4.6	AUX Card (Auxiliary)	43
4.7	I/O Cards (Input/Output Interface)	44



#### 4.1 Rack Motherboard (Fig 4.0 and 4.6 Ref APPENDIX)

The Rack Motherboard can be divided into two sections. Viewed from the front, the left hand section accommodates the PSU card and the main microprocessor cards ie. POS'N, CPU, MEM and AUX.

The right hand section accommodates the I/O (interface) cards, which handle all incoming and outgoing signals.

Although each I/O card is the same, each cards position determines which signals it will be handling. The first 3 cards handle the same information, irrespective of the number of floors, and the remainder handle all the floor variables, two floors per card.

For an 8 floor full collective system, standard rack, there is a total of 7 I/O cards.

#### 4.2 PSU Module (Power Supply) - (Fig 4.0 Ref APPENDIX)

The A.C. voltages are fed from the output of the transformer on the Motor Panel, via a wiring harness, to socket 1T on the Microprocessor Rack, they are then fed as inputs into the PSU Module where they are rectified and fed back to Socket 1T where the various voltages await system use.

The 100V line from the PSU Module is fed via LAR (N.O.) contact on Main Panel, back to LAR (CT2) terminal on Microprocessor Rack, this is then fed via Socket 1C into PSU Module where the output is 'tapped' and fed back to Socket 1C as LPF and CPF signal voltages. (LPF = Landing Push Feed and CPF = Car Push Feed).

The -12V, +10V, +24V and 100V PSU circuit configurations consist of an input fuse protecting a full wave bridge, used for rectification of the A.C. input voltage and a filtering capacitor for 'smoothing' ripple on the bridge D.C. output voltage.

At the output there is a second fuse which protects the output load and an LED with a series current limiting resistor.

The LED acts as a visual indication that an output voltage is present and that if a fuse ruptures the LED will extinguish, giving visual indication that a fuse change is required.

The CPF and LPF are primarily two parallel circuits sourced from a common LAR (CT2) input, which originates from the 100V dc from the PSU module. The return of both circuits being via a link to GND.

CPF output is 'tapped' off between the input fuse and LED series current limiting resistor.

LPF output is 'tapped' off between two series diodes which are situated between the input fuse and LED.

The output voltages from the PSU Module are used in the following applications.

-12V	= RS-232 serial interface communication.
+10V	= Input to the (7805) 5 Volt series regulators on every card except for PSU card. This arrangement in conjunction with the other supplies allows the system to operate down to a 15% reduction in supply voltage.
+24V	= Output relays on the I/O cards.
+100V	= External input signals to the I/O cards.
LPF	= Landing Push Feed
CPF	= Car Push Feed

#### PSU Card Fuse Values

-12V	= +9V AC I/P = 500mA (anti-surge) designated S9N -12V DC O/P = 250mA
+10V	= +9.5V AC I/P = 6.3A (anti-surge) designated S9P +10V DC O/P = 3A
+24V	= +19V AC I/P = 3A (anti-surge) designated S19 +24V DC O/P = 2A
+100V	= +80V AC I/P = 1A (anti-surge) designated S75 +100V DC O/P = 500mA

LPF and CPF = 250mA

### 4.3 CPU Card (Central Processing Unit) - (Fig 4.1 Ref APPENDIX)

The 6808 microprocessor (IC18) is contained on the CPU card and is used for system commands and generating the required system clock.

#### Power-Up and Reset

The RESET signal which is present at the initial start up of the MPU, also disables the RAM (IC12 and IC13) to prevent corruption of the data in the memory. 150mSecs later the RESET signal clears and the MPU begins its reset routine before entering the lift program.

The MPU can be reset manually by means of the RESET PUSH or by the Low Power Supply Voltage Detection Circuit which protects the CMOS RAM during low input voltage situations such as Power-Up and Power Down.

Following the Power Up and Reset procedures, the 6808 microprocessor device sets up its 16 ADDRESS LINES (A0 to A15 inclusive) to the memory location of the EPROM on the MEM Card, which in turn puts a copy of an 8 bit binary number from its fixed program onto the DATA BUS to be read by the microprocessor. The microprocessor then looks up its own internal list, to ascertain which instruction corresponds with this particular binary number, and then carries out that instruction. In total it has 197 different instructions including binary/decimal arithmetic, logical, shift, rotate, load, store and conditional/unconditional branch.

For full description of the microprocessor signals and timings ref. Motorola MC6802/8 Application Note.

#### Power Down

When the input to the 5V Regulator (7805) IC9, falls below 8 volts this is detected by the input to the Low Voltage Detect circuit (8211) IC1, which causes its output to fall disabling the local RAM and resetting the MPU. The 8211 Voltage Detector operates in conjunction with resistors R9, R10, R11 and R12 and its positive going threshold is set to 8.5 volts.

#### Standby Battery Supply

In the event of normal power failure, the local CMOS RAM (IC12 and IC13) is protected for a minimum period of 20 days by the on card 100mAh nickel cadmium battery, which recharges automatically on return of the supply. To enable this back up support the DIL 'BATT' switch must be in the 'ON' position.

The battery charging current is limited to 1mA by the series resistor R14, and the charging current to bulk capacitor C10 or to any short circuit in the standby supply is limited by resistor R13.

The battery should be replaced every 5 years.

#### 4.4 MEM Card (Memory) (Fig 4.2 Ref APPENDIX)

The MEM card can take up to 14K of 2716 EPROM or 6116 RAM and 2K of 2114 RAM (Random Access Memory). There is sufficient Address decoding on the card to enable 42K of EPROM and 6K of RAM to be made available by the addition of two more MEM cards.

IC's 8, 9, 10 and 11 are the RAM's which store data from the Data Bus as well as Read/Write commands. In the event of normal power failure, the RAM is protected for a minimum period of 40 days by a 100mAh nickel cadmium battery, which recharges automatically on return of power.

IC's 1, 2 and 3 are the EPROMs (Erasable Programmable Read Only Memory) which contain the actual lift program, a normal lift program uses 8K of memory. On each EPROM there is a transparent window which allows the program to be erased, if required, by using ultra-violet light, the device can then be re-programmed to include the changes required in the lift program.

When the devices are in the operational mode on the MEM Card, a label covers the window to prevent degradation of the program, by the ingress of ambient U.V. light over a period of time.

A new program can easily be introduced into the system merely by the exchange of EPROM's.

A DIL switch is used to put either a +5 Volt or GRD signal onto the inputs of IC5, A, B, C and D (Pins 1, 4, 10 and 13 respectively), which will enable/disable the WEN (Write ENable), EN (ENable) and CS (Card Select) lines.

## Clock Division

Initially, IC23 accurately divides up the MPU system 0.9216 MHz clock by 24, this is then divided up by IC22B and again by IC22A and IC12A which results in a time pulse count of 0.146 seconds which is used for comparison with the count in the program. A further division of the count by 4 by IC12B, gives the input to the clock indicator which flashes continually, giving a visual indication that the MPU clock is functioning correctly

There is a facility on the MEM Card to allow the MPU to communicate with a VDU/Terminal for visual display of lift status for test/debug purposes, by plugging in an RS-232 serial interface card (RS Card).

### 4.5 POS'N Card (Position) Simplex (Fig 4.3 Ref APPENDIX)

This card indicates the position of the lift by means of two 7-segmented displays.

The direction of the lift is shown by the triangular AMBER indicators.

### 4.6 AUX Card (Auxiliary) (Fig 4.4 Ref APPENDIX)

The AUX Card controls the I/O cards Data Bus and carries peripheral circuit functions via a 40 way ribbon cable. This method results in ease of connection and simplifies multiple rack assembly procedures, as well as allowing a diagnostic unit to be used to control the I/O cards independantly of the microprocessor system.

Sixteen I/O interface cards can be controlled by one AUX card thus giving a total of 128 I/P's and 128 O/P's (Each I/O card contains 8 I/P's and 8 O/P's ie control of two floors per card).

For a 20 floor full collective system only one AUX card is required. A maximum of four AUX cards can be utilized in one system giving a capability of 512 I/P's and O/P's.

The I/O card selection and R/W (READ/WRITE) signals are carried via IC20 and IC21, and the signals from the Data Bus via IC24 and IC 25 through the 40 Way Ribbon Cable to the Interface Cards, where they are implemented. I/P's to the Buffers are from Decoders IC23a and IC23b.

The READ/WRITE circuitry consists of IC's 10, 18 and 19, the O/P's of IC19 determining whether the signal state is READ or WRITE. A '1' output gives a READ signal, and a '0' output gives a WRITE signal.

If a WRITE signal is present one signal (WE1) goes to IC3 (Octal D-type latch) where the output informs the EVENT CODE display of a lift event, and the second WRITE signal (WE2) goes to IC2 (Quad D-type latch) where the O/P's go to TIMER IC1 which generates an audible warning for EVENT CODE display, to COUNTERS IC12a and IC12b which cause the LOOP FLAG LED to flash, and to LOOP FAILURE FLAG. Acknowledge line, which when the LOOP FAILURE MONITOR calls for a reset, will reset the LOOP FLAG.

If a READ signal is present, one signal (RE1) goes to Buffer IC15/16 the O/P's of which are connected to the five push buttons situated on the AUX card, and the second signal (RE2) goes to IC14a CLEAR (Reset) via IC13.

### Watchdog-Loop Flag Monitor

The end command of the main lift program instructs the MPU to go back to the start of the program, this loop continues servicing all the routines and signifies correct operation of the system. IC12 counts the number of loops completed and causes the LOOP FLAG indicator to flash.

If in any event the MPU stays in a particular routine, the LOOP FLAG indicator discontinues flashing and the fault is recognised by the LOOP FAILURE MONITOR IC1b which will reset the MPU, and cause it to re-enter the loop (EVENT CODE '0').

THE MPU, during the reset routine, tests to see if the LOOP FAILURE MONITOR had called for a reset, if so the MPU will generate an EVENT CODE '2'.

### Audible Warning

A warning bleep will occur in conjunction with the EVENT CODE display, whenever an event occurs in the microprocessor system. There is a facility on the AUX card to mute the audible warning by means of the BLEEP DISABLE switch.

### Pushbuttons

Five pushbuttons, P1 to 5 (one red and four blue) are situated on the front of the AUX card and are used for re-calling events which have occurred within the system and other special functions (Ref EVENT CODES SECTION 3, PARA 3.7).

### Door Open Dwell Time (7SR - 7-second Relay)

The time the lift doors park open before automatically closing is adjustable, on site, by potentiometer R13a which controls the timing of IC4.

Also on the AUX card is the I/O card voltage regulator supply fuse. (ISF = 1A anti-surge).

## 4.7 I/O Card (Input/Output Interface) (Fig 4.5 Ref APPENDIX)

Each I/O card consists of 8 I/P's and 8 O/P's each having an LED indicator (Ref. SECTION 3 PARA 3.1.5). Each I/P is sourced from 100V dc and is opto-isolated. Each O/P uses a relay capable of switching 250 Volts ac at 5 amps.

Every incoming and outgoing signal, together with the I/P's, has the capability of withstanding wrong connections, a 500V Megger Test, Bell Buzzer or a short circuit.

## Input Interface

With reference to circuit with input designator of INO. Resistor R15 (5K6) limits the input current to 10mA from the 100V dc input supply, this still being sufficient to illuminate the LED indicator LED1 and the opto-isolator LED. The series zener diode Z1 (27 Volts) prevents in effect any current smaller than 10mA from operating the circuit, the zener cathode clamp voltage being approximately 30V dc. The 0.47uF capacitor reduces any interface transients.

Diode, D1, is a safety device for protecting LED's and the capacitor against any negative going input signals caused by transients or incorrect connection of an A.C. signal.

Resistor R12 (5k) is a permanent input load, attenuating any induced voltage onto the line.

RN1 (22K) is a pull up resistor, connected to the collector of the photo-transistor (Pin 15), which pulls the line to a level '1' into IC7, Pin 5, when the transistor is not conducting. When the opto-isolators LED is illuminated, causing the photo-transistor to go into full conduction, a level '0' goes into IC7, Pin 5.

The system monitors all I/P signal changes, if the I/P signal state does change, the system executes a 3 'loop' check i.e. the signal state is checked three times to verify it is a valid signal state change before it is accepted into the remainder of the system.

If during this 'loop' check, the signal state changes, the system will not accept it as a valid signal and ignores it. Such an event could occur due to relay contact bounce during relay energisation.

A pushbutton is shown across the O/P of the opto-isolator, so that the input signal can be simulated manually. (ref. SECTION 2 PARA 2.10). In practice this pushbutton has been replaced by two board pins. IC6 and IC7 are 3 STATE BUFFERS (74LS126) i.e. they have 3 stable states, a logic '1' level, a logic '0' level and a state where the O/P becomes high impedance therefore effectively disconnecting itself from whatever load it is driving. This means that the outputs of several 3-state devices can be commoned together and only one output enabled to sense the level of the I/P signal of the selected device.

There are 8 separate information lines per interface card, designated D0 to D7 inclusive and are called the 'DATA BUS' which are connected to the 3-state Buffers.

The logic levels present at the 8 opto-isolator O/P's are put onto the 'DATA BUS' when a logic level '1' from IC10B (READ) enables IC6 and IC7, this information is routed to the MPU on the CPU card via the AUX card and DATA BUS, where each I/O card is selected in turn by the MPU to gather all the incoming signals.

## Output Interface

Data written from the MPU is retained by IC4 and IC5 (74LS75 D-type latches).

When the 'enable input' is high the input data appears at the outputs and when the 'enable input' goes low the data is retained.

The inverted O/P's drive the output relays ie IRO via Q1 and IRI to IR7 inclusive via IC3.

The relays 'COMMON' contact are commoned on all O/P's and protected by an on-board 5 Amp fuse, designated OIF.

The N.O. (normally open) contacts go to O/P's OTO to OT7 inclusive.

The output relays can be operated independently of their drives, by use of the test points at the outputs.

In parallel with each relay is an LED with a series current limiting resistor, which gives a visual indication of its state i.e. illuminates when relay energised.

All O/P signals can be set by the MPU by 'writing' to each interface card in turn.

## Input Level Detection

The incoming signal must exceed 50 to 75V dc at the I/P interface before IC6 and IC7 recognize it as a valid signal.

## Interface Card Select

For Buffers IC6 and IC7 to become enabled the O/P of IC10B (READ) must go to a level '1', for this to occur signals from CS and G must be at a level '0' and the R/W and Ø3 to be at a level '1'. Fig 4.6 shows which interface card is selected by CS and G signals.

To select an I/O card, the MPU firstly, by using the CS0, CS1 and CS2 lines, selects a group of 4 cards, then by using the G0, G1 and G2 lines it singles out the required card.

The R/W (READ/WRITE) control signal is important and is at a level '1' for the MPU to 'READ' and at a level '0' for the MPU to 'WRITE'.

IC4 and IC5 would become enabled if, when the I/O card was selected R/W had been at a level '0'.

The Buffers or the 74LS75 latches are enabled by Ø3, at the correct time, when data is being 'read' or 'written' and is related to the MPU clock signal.

SECTION 5

OVERHAUL AND REPAIR

		Page
5.1	Handling of EPROMS	48
5.2	Fault Finding Procedures	48

TABLES

		Page
TABLE 1	SELECTED LED STATUS CORRESPONDING TO LIFT OPERATIONS	51



## 5.1 Handling of EPROMS

WARNING 2716 EPROMS ARE MOS DEVICES WHICH REQUIRE CAREFUL HANDLING IN THE REMOVAL AND INSERTION STAGE, AS THEY CAN EASILY BE DAMAGED BY STATIC ELECTRICITY.

To remove an EPROM, firstly remove the card from the microprocessor rack, then place one hand on the regulator heatsink (this will discharge any build up of static electricity that may be present within the body) and EPROM which is to be removed. With a small blade under one end of the device ease it until it is almost out of the DIL socket. While one hand is still on the heatsink, remove the EPROM with the fingers in contact with as many pins on the EPROM as possible with the other hand. Whilst holding the EPROM with the one hand, transfer the other to the conductive foam and then insert the EPROM into the foam.

Similar care should be taken inserting the replacement EPROM into the DIL socket.

The aim of this procedure is to ensure that the potential between the human frame and the device is zero.

## 5.2 Fault Finding Procedures

### Initial Checks

- (1) Ensure all power supplies on  $\mu$ P are operating satisfactory.
  - (a) 100V d.c. supply LED illuminated on power board.
  - (b) 24V d.c. supply LED illuminated on power board.
  - (c) 10V d.c. supply LED illuminated on power board.
  - (d) 5V d.c. supply LED illuminated on each board.

If the power supply LED's are extinguished, check the fuses on the power supply card (situated in holders at the front of the card and mounted on the card). If fuses persist to blow, remove all cards except the power supply card and re-insert one card at a time until fault is localised to a card which can then be replaced.

- (2) Check clock flag is pulsing on CPU card proving that basic timings for  $\mu$ P are available.
- (3) Check loop flag is pulsing on AUX card proving that the  $\mu$ P programme is continually scanning its programme loop.

If this condition cannot be achieved then the AUX, CPU MEM and POSN cards should be replaced individually until faulty card is located. Remember when replacing the MEM card that the EPROMS contained on the original card must be moved into the test replacement card (EPROMS have labels with contract details covering a glass window, label must not be removed). If satisfactory operation of the loop and clock flag indicators is not achieved then replacement EPROMS must be tried, and closer monitoring of the power supplies must be carried out, this time with a meter.

- (4) Having achieved pulsing operation of the clock and loop flags, attention should be turned to the I/O cards. Ensure loom is firmly inserted between the AUX card and the back of the mother board. Individual testing of each I/O card may now be obtained by the following procedure:-
- (a) Remove the first I/O card on left (containing LAR, HSR, signals).
  - (b) Operate together, and continuously the red reset and engineers entry pushes on the AUX card.
  - (c) For a period of approx. 5-10 seconds any input operated on an I/O card (by push or shorting pins at front of card) will be 'written' to operate the corresponding relay output on the same card (i.e. top input operates top relay).

This action proves that the  $\mu$ P programme is scanning its inputs and writing to its corresponding outputs using its basic programme and hardware facilities.

After 5-10 seconds the engineers/reset buttons on the AUX card must be released and re-operated to continue further I/O card testing.

This test checks the primary operation of the  $\mu$ P structure and also a major section of the I/O card. It does not test the initial opto-isolater input stages of the I/O card, nor relay output contact wiring.

- (5) With all cards inserted into the rack the lift should be ready for initial operation.

Switch the lift to car top test and observe the LED signals on the I/O cards. Check that the selected I/O signals are as TABLE 1 'LIFT STATIONARY ON TEST'.

If LED's are not as described then check voltages to terminals at rear inputs to rack to verify that external signals are correct. If I/O card LED's do not coincide with input terminal voltages then looms to cards should be checked (by hinging down rear terminal board to rack) or cards replaced to isolate fault.

- (6) Door Operation

Door open and close operation on normal service is controlled by output signals DOPR and DCLR respectively. With doors closed DCLR, GL, and DZ if in door zone, should be illuminated. Operation of SE or DOP signal on normal service should operate DOPR signal to open the doors providing DZ signal is present (lift in door zone). When doors open first GL and then DZ are extinguished. If lift is on normal service then after approx 7 seconds (adjustable by 7SR dwell timer) the doors should park closed.

(7) Selector Operation

Selector reset operation may be checked by running the lift into each terminal floor. The presence of SSU, and U signals will give a top floor reset and SSD and D will give a bottom floor reset.

Running the lift on car top test between terminal floors should update selector position by signal inputs U and MRU for up stepping, or D and MRD for down stepping.

(8) Starting on High Speed

Providing the signal status for 'LIFT STATIONARY ON NORMAL DOORS CLOSED' as TABLE 1 are established then the lift may be prepared for starting. Operation of a call to move the lift should operate IU, SRU signals for up starting or ID, SRD signals for down starting. Operation of SRU, SRD will instruct the main motor control section to operate U or D signals to the  $\mu$ P rack (see TABLE 1 'LIFT MOVING ON NORMAL').

(9) Moving and Slowdown

As the lift travels with a U or D signal present then as the appropriate MRU or MRD signal is operated by shaft switches the selector position is updated.

When the lifts position is coincident with a call then SRU/SRD is released on the trailing edge of the MRU/MRD signal to instruct the main panel to slowdown.

As the lift approaches the floor the levelling signals on the main panel establish a DZ signal, to give a DOPR signal to the main panel for door opening (see TABLE 1 'LIFT IN DOOR ZONE').

TABLE 1 - SELECTED LED STATUS CORRESPONDING TO LIFT OPERATIONS

Selected I/O Signals	LED Status				
LAR	OFF	ON	ON	ON	ON
DCLR	OFF	ON	ON	ON	OFF
DOPR	OFF	OFF	OFF	OFF	ON
DOP	OFF	OFF	OFF	OFF	OFF
DZ	ON IF IN DOOR ZONE	ON IF IN DOOR ZONE	OFF	OFF	ON
GL	ON IF LOCKS MADE	ON	ON	ON	ON
SE	OFF	OFF	OFF	OFF	OFF
SRU	OFF	OFF	ON FOR UP	OFF	OFF
SRD	OFF	OFF	ON FOR DN	OFF	OFF
HSR	OFF	OFF	ON	OFF	OFF
MRU	ON IF PROX OPERATED	ON IF PROX OPERATED	ON IF PROX OPERATED	OFF	OFF
MRD	ON IF PROX OPERATED	ON IF PROX OPERATED	ON IF PROX OPERATED	OFF	OFF
SSU	ON IF AT TOP FLOOR	ON IF AT TOP FLOOR	ON IF AT TOP FLOOR	ON IF AT TOP FLOOR	ON IF AT TOP FLOOR
SSD	ON IF AT BOT FLOOR	ON IF AT BOT FLOOR	ON IF AT BOT FLOOR	ON IF AT BOT FLOOR	ON IF AT BOT FLOOR
CP1-(N)	OFF	ON IF CALL OPERATED	ON IF CALL OPERATED	ON IF CALL OPERATED	ON IF CALL OPERATED
L1U-L(N)U	OFF	ON IF CALL OPERATED	ON IF CALL OPERATED	ON IF CALL OPERATED	ON IF CALL OPERATED
L2D-L(N)D	OFF	ON IF CALL OPERATED	ON IF CALL OPERATED	ON IF CALL OPERATED	ON IF CALL OPERATED
U	OFF	OFF	ON FOR UP	ON FOR UP	ON FOR UP
D	OFF	OFF	ON FOR DN	ON FOR DN	ON FOR DN
SSR	OFF	OFF	OFF	OFF	OFF
IU	OFF	OFF	ON FOR UP	ON FOR UP	ON FOR UP
ID	OFF	OFF	ON FOR DN	ON FOR DN	ON FOR DN
	LIFT STATIONARY ON TEST	LIFT STATIONARY ON NORMAL DOORS CLOSED	LIFT MOVING ON NORMAL	LIFT SLOW ON NORMAL	LIFT IN DOOR ZONE



SECTION 6

SPARES LIST



SECTION 7

DUPLEX OPERATION

		Page
7.1	Reference to Duplex Operation	56
7.2	Communication Cable Connection	56
7.3	Technical Description (POS'N Card - Duplex)	57



## 7.1 Reference to Duplex Operation

The Duplex system consists of two Simplex lift control panels communicating with each other via a special interconnecting cable. The landing calls are then handled between the two lifts.

If the interconnection is unplugged, the two lifts lose communication with each other, and both assume Simplex operation.

After installation has been completed on the first lift of a Duplex system, it can be commissioned for use i.e. Simplex operation, whilst the second lifts installation is being completed. The connecting of the communications cable and the landing calls, LPF, LAF and INR is done last to achieve Duplex operation.

There is a common Landing Call Acceptance Feed (LAF) between lifts.

Therefore one lift can work in the Simplex mode whilst the other lift is switched off for maintenance work etc.

CAUTION: The reader should be aware that the LPF (100V), LAF (12V dc) and transitory signals from the landing call pushes of the lift, which is switched off, are still live because they are being sourced from the operational lift.

## 7.2 Communication Cable Connection

The following procedure should be adhered to when connecting up the communications cable.

- (a) Switch off system.
- (b) Disconnect green/yellow wire from POSN Card.
- (c) Remove POSN Card.
- (d) Remove Power Supply Module.
- (e) Pass the communication cable plug through the hole in bottom plate of rack, from underneath.
- (f) Re-insert Power Supply Module.
- (g) Re-insert POSN Card.
- (h) Re-connect green/yellow wire onto POSN Card (spade connector).
- (j) Plug communications cable into socket on the POSN Card, whilst supporting the card with the other hand.
- (k) Ensure that the DIL switch (CTS), on the POSN Card is set forward toward the card handle.

POS'N Card (Position) Duplex - (Fig 7.0 Ref APPENDIX)

This card indicates the position of the lift by means of a 7-segment display, used to indicate lift position and a 6-segment display for indicating lift position and lift direction.

The 7-segment display is used for indicating lift position up to and including the ninth floor, if this level is exceeded e.g. 12 floors, the lift program will illuminate the "1" in the 6-segment display and the "2" in the 7-segment display (19 floors being maximum that can be indicated with these displays).

The "+/-" on the 6-segment display is used to indicate the lifts direction ie "+" = UP direction and "-" = DOWN direction.

The Duplex system requires additional components on the POS'N Card which are not included for Simplex operation.

The Asynchronous Communications Interface Adaptor (ACIA) designated IC19, sends and receives serial data transmissions via an RS-232 interface to and from the other lift.

The ACIA transmits data serially via an opto-isolator and line driver (designations IC9 and IC8D respectively). The line drivers output is connected to the other lifts receiver input (opto-isolator IC7) via a pre-made interconnecting cable.

A visual indication that signals are being received from the other lift is by means of a red indicator LED (LED 4) glowing dimly, which is connected across the input of IC7, its position on the card being at the rear of the LED pair. The output of IC7 is fed into a line receiver (IC13B) which employs response control and hysteresis.

When LED 3, situated in front of the LED pair, is off it indicates that it is "Clear to Send" data. The 'CTS' switch should be set forward toward the card handle so that the input to the ACIA of the other lift is low.

If the communication cable between the two lifts is unplugged the output of IC6 will go high, thus indicating that it is NOT "Clear to Send". The lift program will then assume Simplex control over all landing calls.

Note: It is important that the transmission and receiving clock frequencies are the same on both lifts, as well as:

- (a) the MPU crystal.
- (b) the 'clock division' link.
- (c) the 'Baud Rate' link.

items (b) and (c) being on the MEM card.

The required 'Baud Rate' clock frequencies are produced on the MEM (Memory) Card, and are fed from the RS-232 Serial Interface (RS Card) to the POS'N Card.

The actual Duplex lift program is held in IC1, IC2 and IC3 (EPROMS) on the MEM Card, the same as for Simplex operation.

The Green LED when illuminated indicates that the 5V logic supply is available to the card.

SECTION 8

GLOSSARY OF TERMS

		Page
8.1	Input Signal Abbreviations	60
8.2	Output Signal Abbreviations	61
8.3	System Abbreviations	62

Abbreviations as per perspex front cover (Input/Output Signals)

8.1 Input Signal Abbreviations

LAR	=	Lift Available Relay
OC	=	Door Open Contactor
CC	=	Door Close Contactor
DZ	=	Door Zone Relay
U	=	Up Contactor
D	=	Down Contactor
GL	=	Gate Locked
WS2	=	Weight Switch set at 110% Full Load
WS1	=	Weight Switch set at 95% Full Load
HOM	=	Homing Switch - takes lift to ground floor
SSR	=	Service Control Relay
ATS	=	Attendant Control Switch
AU	=	Attendant Up Push
AD	=	Attendant Down Push
BP	=	Attendant Bypass Switch
FS2	=	Firemans Switch
DCP	=	Door Close Push
SSU	=	Top Floor Reset
SSD	=	Bottom Floor Reset
SE	=	Door Safety Edge
DOP	=	Door Open Push
BB	=	Beam Broken (Light Ray)
CP1	=	Car Push Input - 1st Floor
L1U	=	Up Landing Push Input - 1st Floor
L2D	=	Down Landing Push Input - 2nd Floor
PTT	=	Prepare To Take Out
ANUI	=	Anti Nuisance Inhibit
MRHX	=	Step Prox High Speed
MRMX	=	Step Prox Med Speed
MRLX	=	Step Prox Low Speed
MSFR	=	Mid Shaft Floor Reset
CFS	=	Car Call Feed Supply
LFS	=	Landing Call Feed Supply
LISE	=	Lift In Service Enable
DPK	=	Down Peak Time Switch Input
UPK	=	Up Peak Time Switch Input
AFS	=	Alternative Fire Floor Signal
EQK	=	Earthquake Emergency Stop Signal

For U.S. Market Only:

FS4	=	Fire Control Phase 2
RST	=	Card Call Reset

Output Signal Abbreviations

HSR	=	High Speed Relay - used for multiple high speeds only
SUR	=	Speed Up Relay - energises to initiate the lift for 'UP' direction
SDR	=	Speed Down Relay - energises to initiate the lift for 'DOWN' direction
LSA	=	Lift Service Available Relay - energises after all other safety contacts are closed
DOPR	=	Door Open Relay - energises to open the doors
ROPR	=	Rear Open Relay - energises to open rear of lift
DCLR	=	Door Close Relay - energises to close the doors
DBZ	=	Door Nudging Zone Buzzer
BPI	=	By Pass Indicator
HLU	=	Hall Lantern Up
HLD	=	Hall Lantern Down
AGR	=	Arrival Gong Relay
BZ	=	Attendant Control Buzzer
FCI	=	Fire Control Indicator
IU	=	Up Direction Indicator
ID	=	Down Direction Indicator
PI1	=	Position Indicator - Floor 1
CA1	=	Car Call Acceptance - Floor 1
I1U	=	Landing Call Acceptance - Floor 1 'UP'
I2D	=	Landing Call Acceptance - Floor 2 'DOWN'
FSX	=	Fire Service Pilot
FCR	=	Fire Service Return
TCN	=	This Car Next
HMF I	=	Heavy Main Floor
HDDI	=	Heavy Down Demand

System Abbreviations

LFF	=	Loop Flag Failure
ISF	=	Input Supply Fuse - on AUX Card for I/O Cards
MPU	=	Microprocessor Unit
LFM	=	Loop Failure Monitor - on AUX Card
LMI	=	Loop Monitor Inhibit
LAF	=	Landing Call Acceptance Feed
CPF	=	Car Push Feed
LPF	=	Landing Push Feed
7SR	=	Door Open Dwell Time (7 second relay)
R/W	=	Read/Write
VMA	=	Valid Memory Address - Microprocessor Control Signal
LISI	=	Lift In Service Indicator
INR	=	Common Indicator Return
CTS	=	Clear to Send
LSTLR	=	Low Speed Time Limit Relay
PFRR	=	Phase Failure and Reversal Relay
PUR	=	Pilot Up Relay
PDR	=	Pilot Down Relay
CS	=	I/O Card Selects - selects a group of four cards
G	=	I/O Card Select - singles out the required card.
MRU	=	Up Step Proximity Switch
MRD	=	Down Step Proximity Switch

## APPENDIX

### ILLUSTRATIONS

Fig 2.0	External Wiring (Microprocessor to rest of system)
Fig 2.2	Main Panel Wiring Diagram
Fig 4.0	PSU Module Circuit Diagram
Fig 4.5	I/O Card Circuit Diagram



Issue 1  
Date 3/85



SUPPLY  
415 VOLTS  
3 PH 50 HZ 4 WIRE  
N L1 L2 L3

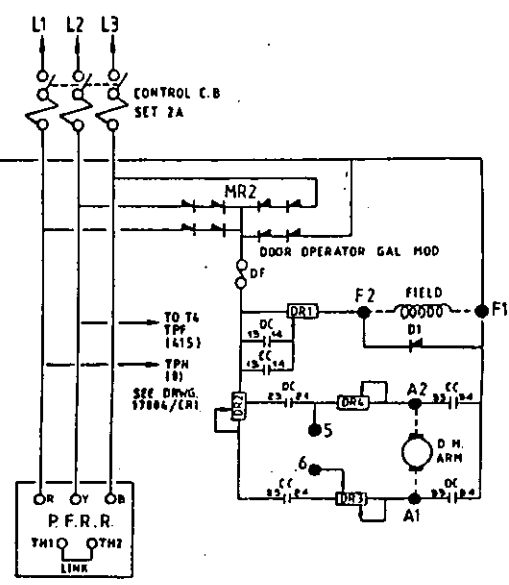
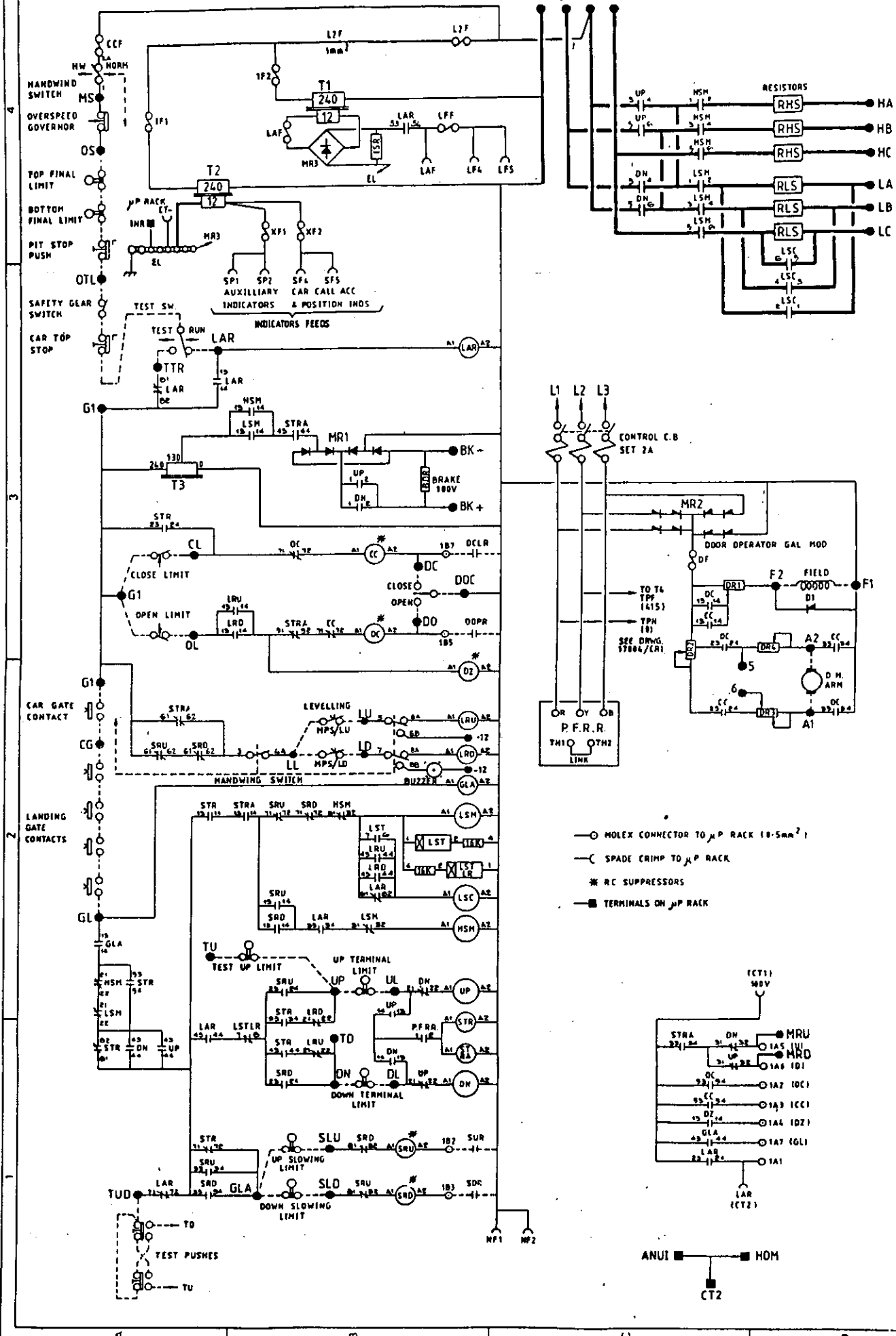

- MOLEX CONNECTOR TO  $\mu$ P RACK (18-5mm<sup>2</sup>)
- SPADE CRIMP TO  $\mu$ P RACK
- \* RC SUPPRESSORS
- TERMINALS ON  $\mu$ P RACK

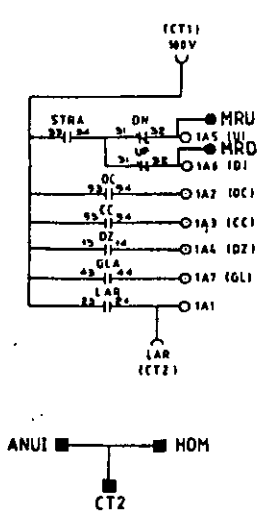

CONTRACT NO.

Fig 2-2

MICROPROCESSOR COLLECTIVE  
MOTOR PANEL SCHEMATIC

ORG. NO.



4  
3  
2  
1

- 43 ●
- 42 ● 017
- 41 ● 016
- 40 ● 015
- 39 ● 014
- 38 ● 013
- 37 ● 012
- 36 ● 011
- 35 ● 010
- 34 ● 01F
- 33 ●
- 32 ● 124
- 31 ● 104
- 30 ● 10M
- 29 ● D7
- 28 ● D6
- 27 ● D5
- 26 ● D4
- 25 ● D3
- 24 ● D2
- 23 ● D1
- 22 ● D0
- 21 ●
- 20 ●
- 19 ● C3
- 18 ●
- 17 ●
- 16 ●
- 15 ●
- 14 ● 104
- 13 ● 103
- 12 ● GND
- 11 ● GND
- 10 ● C
- 9 ● IN7
- 8 ● IN6
- 7 ● IN5
- 6 ● IN4
- 5 ● IN3
- 4 ● IN2
- 3 ● IN1
- 2 ● IN0
- 1 ●

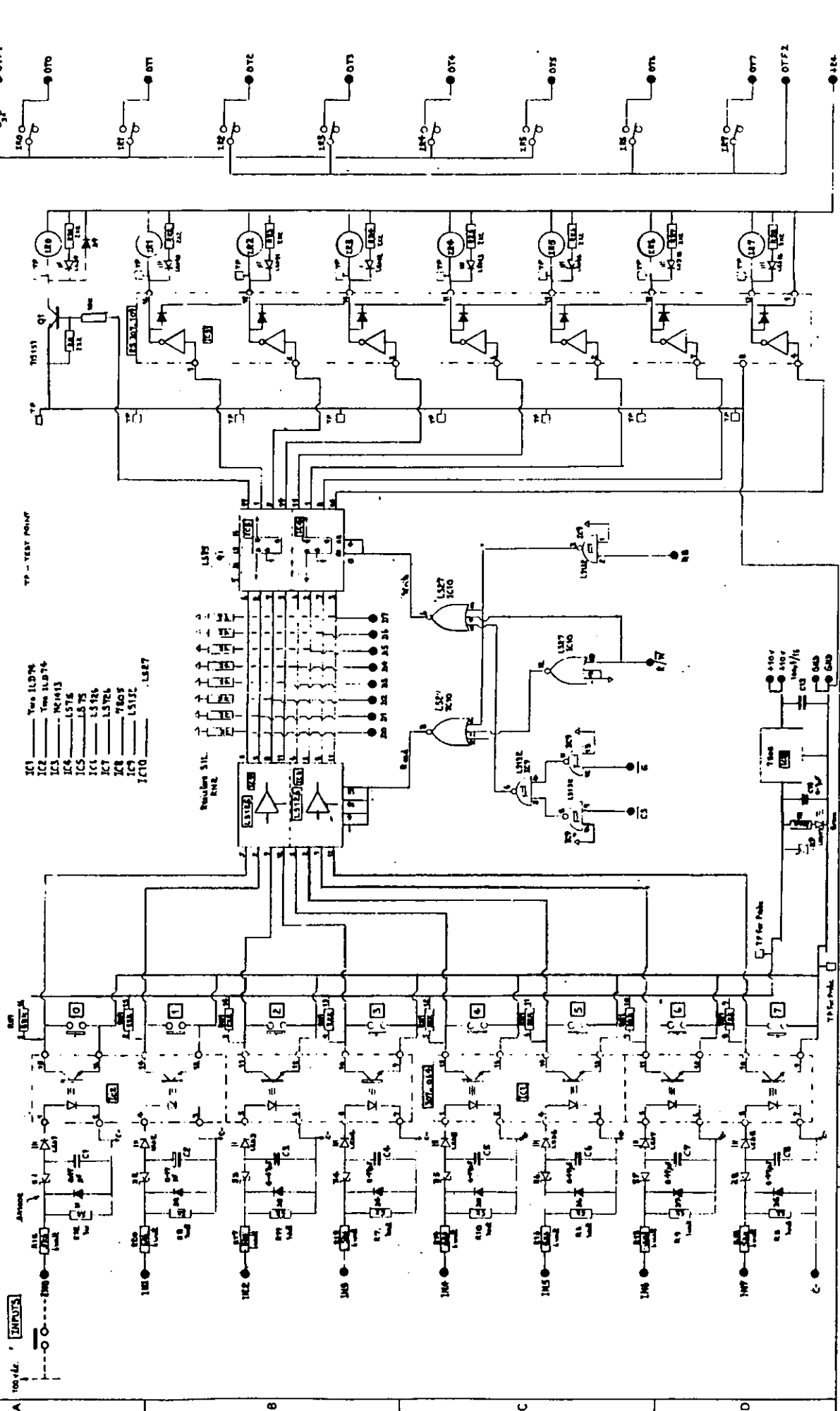

DRG. NO. 17004/10

CONTRACT NO. \_\_\_\_\_

REV. A	DATE	SCALE	MAN. LIST
REV. B	DATE	SCALE	MAN. LIST
REV. C	DATE	SCALE	MAN. LIST
REV. D	DATE	SCALE	MAN. LIST

FIG. 4-5

INTERFACE BOARD

COPYRIGHT & CONFIDENTIAL

DESIGNED BY: \_\_\_\_\_

TRACED BY: \_\_\_\_\_

TESTED BY: \_\_\_\_\_

APPROVED BY: \_\_\_\_\_

DATE: \_\_\_\_\_

SCALE: \_\_\_\_\_

MAN. LIST: \_\_\_\_\_

FIG. 4-5